

CUSTOMER

# CAN ART STD.

DIE No.

EH05960

REV. No.

1

DESCRIPTION

2" x 2" x .250" THK. ROUNDED INSIDE/OUTSIDE CORNERS

CUSTOMER PART No.

QUOTE No.

10-0128-2

PROPOSAL No.

H-22295

NOTE: BREAK ALL CORNERS WITH 0.015" (.38 MM) RADIUS UNLESS OTHERWISE NOTED. STANDARD TOLERANCES TO APPLY UNLESS OTHERWISE SPECIFIED.

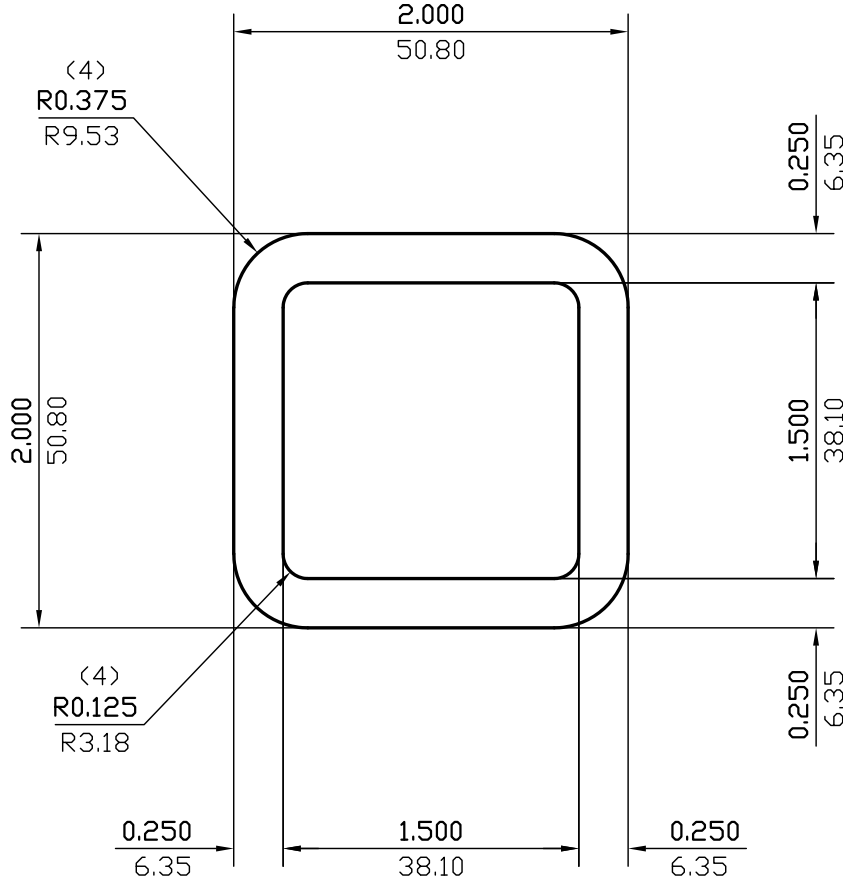

WALL THICKNESS 0.250(6.35) EXCEPT AS SHOWN

DATE	REV	DESCRIPTION	BY
03/13/23	1	REMOVED ALLOY	JASON
EST.AREA	1.643	IN. <sup>2</sup>	EST.AREA 1059.812
			MM. <sup>2</sup>
EST.WT.	1.938	LBS/FT.	EST.WT. 2.885
			KG/M.
EST.PER.	13.142	IN.	EST.PER. 333.796
			MM.
OUT PER.	7.356	IN.	OUT PER. 186.8
			MM.
C.C.D.	2.518	IN.	C.C.D. 63.951
			MM.
FINISH	M/F		ALLOY
CKD BY	FACTOR 7	SCALE 1:1	DWN BY C.P. DATE 02/16/2010

## CAN ART

ALUMINUM EXTRUSION INC.

85 PARKSHORE DRIVE  
BRAMPTON, ONT L6T 5M1  
TEL. NO. (905) 791-1464  
FAX NO. (905) 791-9151  
WEB: www.canart.com

THIS DRAWING IS NOT NECESSARILY A COPY OF YOUR ORIGINAL. PLEASE APPROVE DIMENSIONS AND TOLERANCES INDICATED. CAN ART ASSUMES NO RESPONSIBILITY EITHER TECHNICAL OR LEGAL FOR HAVING THIS SHAPE MADE. THE CUSTOMER AGREES TO FULLY PROTECT CAN ART ALUMINUM FROM CLAIMS OF OTHERS RESULTING FROM THIS SHAPE.

SIGNED: \_\_\_\_\_ DATE: \_\_\_\_\_